

e-mail: podymov@coastdyn.ru, tpodymova@inbox.ru

(),

(, 2003).

-
-

5

InGaAlP
-18 (Ø 5.6)

OP-651
650 ,

OP -651

. 1.

ADP1110

VT1-VT2,

()

3,5 5

(. 2)

(. 2)

LD.
R1.

U

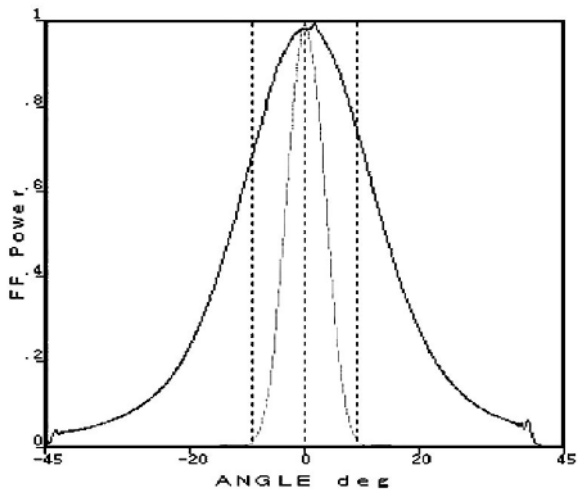

. 1.

OP-651

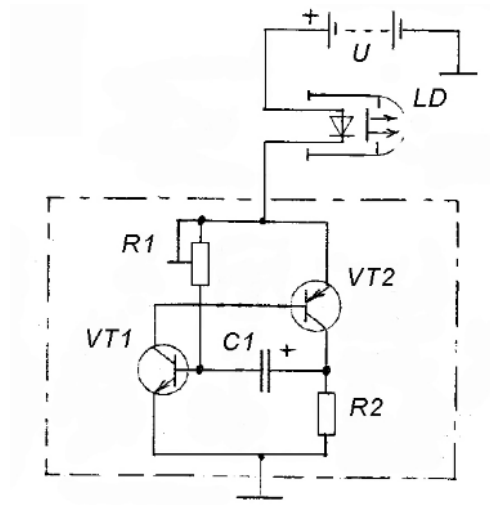

. 2.

(10).

(. 3),

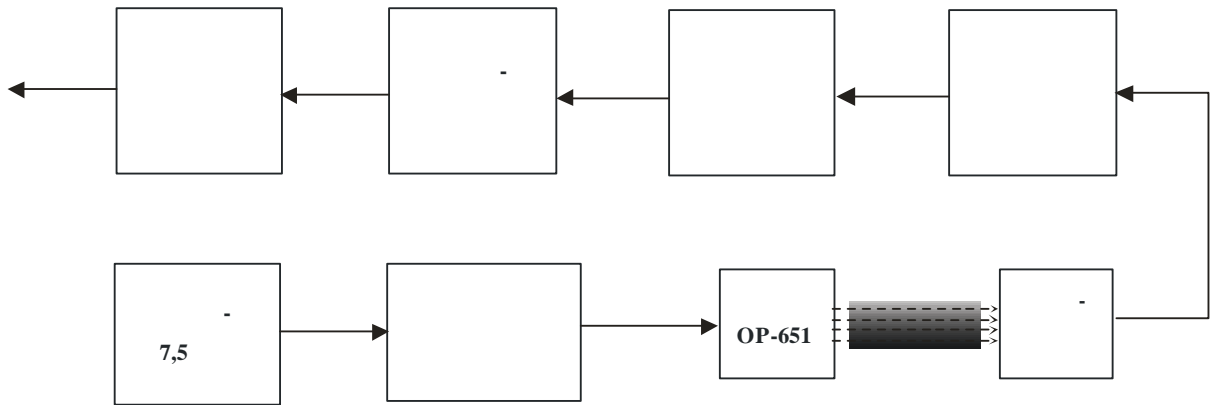

. 3.

3,5 .

09-05-00132.

« . . . » , 2003, . . 15-27. « . . . » .