

che-chko@mail.ru, piwis@mail.ru

The basic methods of study of eolian material in the coastal zone of south-east part of the Baltic sea are presented. The methods of collection and pretreatment of eolian material, settleable on a water surface in natural way are described; washed from an atmosphere by snow and rain; carried from shore at sea by skyway at extreme gales.

[5].

[2, 8, 9, 18]

[7, 11, 12, 14].

[1].

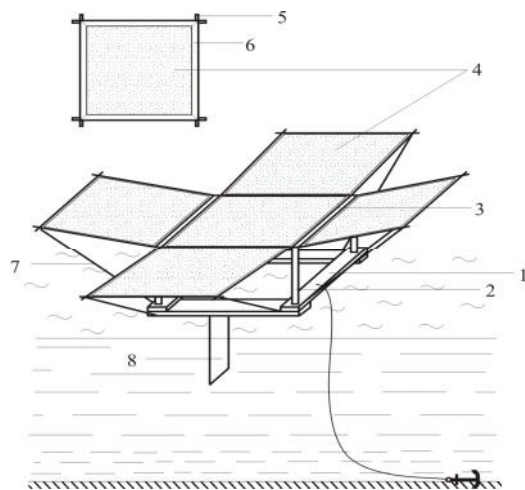

1 – , 2 – , 3 – , 4 – ,
 5 – , 6 – , 7 – , 8 –

(24)

47 0,45

GF/F.

[3, 17].

[4], . . ,

(62) .

[11, 12].

« »

100 100

0, 45

GF/F,

[10],

326³

1

(. 2).

1

28

45

2

180

3,

4,

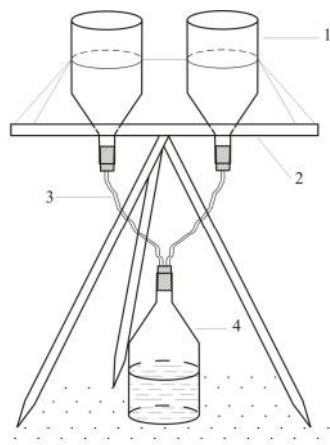

.2

1 -

; 2 -

; 3 -

; 4 -

, ()
 , ,
 .
 .
 , ,
 , ,
 «POLCA» [16]. 20, 50, 100, 150 200
 -
 , ,
 ,
 .

1. , 1990. 272 .
2. . „ , 1993. 304 .
3. . „ . „ : - , 1993. 157 .
4. . „ // . 2005. .45. 5. .777-784.
5. . „ . „ . „ //
6. : - , 2004. . 42 – 46.
7. . „ // . „ : , 1974. . 259 – 279.
8. . 1. // . 2004. . 17, 1. . 5 – 24.
9. . „ : , 1974. 438 .
10. . „ : , 1978. 392 .
- // . 1953. . II, 2. . 401- 403.

11. , 2006. 226 .
12. //
– . 2000. . 13, 6/7. . 551 – 575.
13. // . 2008. 11. . 85-89.
14. Brimblecombe P. Air composition and chemistry. Cambridge: Cambridge Univ. press, 1996. 253 p.
15. Chester R., Johnson L. R. Atmospheric dust collected off the West African coast // Nature. 1971. Vol. 229. P.105 -107.
16. Goossens D., Offer Z., London G. Wind tunnel and field calibration of aeolian sand traps // Geomorphology. 2000. 35. P. 233-252.
17. Lisitzin A.P. Sea-ice and iceberg Sedimentation in the ocean: Recent and past. Berlin; Heidelberg: Springer-Verlag, 2002. 563 p.
18. Swap R., Ulansk I S., Cobett M., Garstang M. Temporal and spatial characteristics of Saharan dust outbreaks // J. Geophys. Res. D. 1996.V.101. 2. P. 4205 – 4220.